

# 150R/T/B

## Operator's Manual



CMW®

Issue 1.0



053-1105

---

# Overview



## Chapter Contents

<b>Serial Number Location</b> . . . . .	<b>2</b>
<b>Intended Use</b> . . . . .	<b>3</b>
<b>About This Manual</b> . . . . .	<b>3</b>
• Bulleted Lists. . . . .	3
• Numbered Lists . . . . .	3
• "Continued" Indicators. . . . .	3

## Serial Number Location

Record serial numbers and date of purchase in spaces provided. Unit serial number is located as shown.

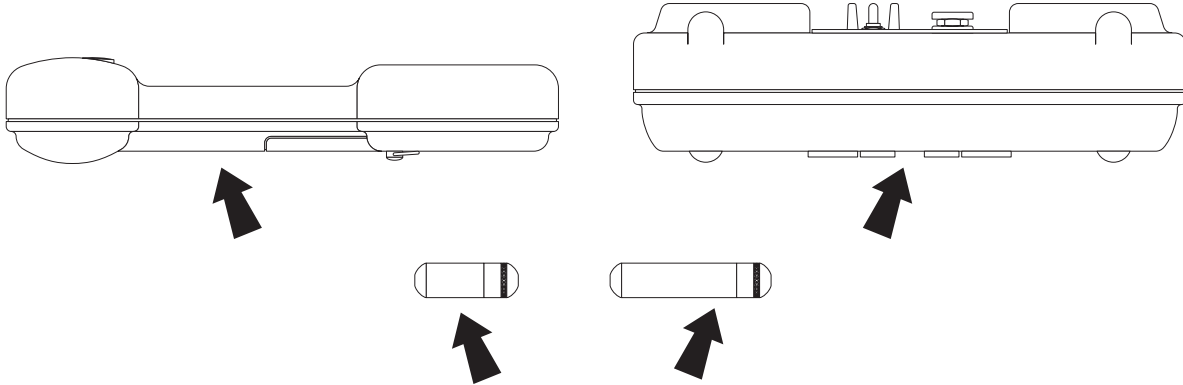

e07om020a.eps

Item	
date of purchase:	
receiver serial number:	
transmitter serial number:	
accessory model & serial number:	
accessory model & serial number:	
accessory model & serial number:	

## Intended Use



The system can be configured to locate pipe and cable or trace metallic and non-metallic pipe or conduit.

The 150R receiver is available in peak or null configurations. Units configured to operate in the peak mode will have one active frequency (640Hz, 30kHz or 83kHz) as well as 60S and 60P. Units configured to operate in null mode will only have one frequency (83kHz).

The 150T transmitter places signals on target lines to be detected by 150R receivers. It is configured to send 30kHz or 83kHz frequencies. It places a signal on the line through either direct connection, induction clamping, or broadcast modes.

The 150B beacon broadcasts a signal from a metallic pipe, non-metallic pipe or conduit. It is available in two different frequencies (640Hz, 30kHz). The beacon is attached to a flex rod, placed into a pipe and tracked with the 150R receiver.

The unit is designed for operation in temperatures typically experienced in earth moving and construction work environments. Use in any other way is considered contrary to the intended use. The 150 system should be operated only by persons familiar with its particular characteristics and acquainted with the relevant safety procedures. The system should be serviced only by Subsite repair centers.

## About This Manual

This manual contains information for the proper use of this equipment. Cross references such as "See page 50" will direct you to detailed procedures.

### Bulleted Lists

Bulleted lists provide helpful or important information or contain procedures that do not have to be performed in a specific order.

### Numbered Lists

Numbered lists contain illustration callouts or list steps that must be performed in order.

### "Continued" Indicators



indicates that a procedure is continued on the next page.



---

# Foreword



This manual is an important part of your equipment. It provides safety information and operation instructions to help you use and maintain your Subsite equipment.

Read this manual before using your equipment. Keep it with the equipment at all times for future reference. If you sell your equipment, be sure to give this manual to the new owner.

If you need a replacement copy, contact your Subsite dealer. If you need assistance in locating a dealer, visit our website at **www.subsite.com** or write to the following address:

The Charles Machine Works, Inc.  
Attn: Subsite  
PO Box 66  
Perry, OK 73077-0066  
USA

The descriptions and specifications in this manual are subject to change without notice. The Charles Machine Works, Inc. reserves the right to improve equipment. Some product improvements may have taken place after this manual was published. For the latest information on Subsite equipment, see your Subsite dealer.

Thank you for buying and using Subsite equipment.

**150R/T/B  
Operator's Manual**

**Issue number 1.0/OM-10/06**

**Part number 053-1105**

**Copyright 2006**

**by The Charles Machine Works, Inc.**

Subsite is a registered trademark of The Charles Machine Works, Inc.

# Contents



	<b>Overview</b> machine serial number, information about the type of work this machine is designed to perform, basic machine components, and how to use this manual	<b>1</b>
	<b>Foreword</b> part number, revision level, and publication date of this manual, and factory contact information	<b>5</b>
	<b>Safety</b> machine safety alerts and emergency procedures	<b>9</b>
	<b>Controls</b> machine controls and how to use them	<b>13</b>
	<b>Locate</b> procedures for locating active, passive and beacon signals	<b>25</b>
	<b>Locating Concepts</b> basic information for locating active, passive and beacon signals	<b>39</b>
	<b>Service</b> service intervals and instructions for this machine	<b>43</b>
	<b>Specifications</b> machine specifications including weights, measurements and power rating	<b>49</b>
	<b>Support</b> the warranty policy for this machine, and procedures for obtaining warranty consideration and training	<b>53</b>





---

# Safety

## Chapter Contents

Guidelines . . . . .	10
Safety Alert Classifications . . . . .	11
Safety Alerts . . . . .	12



## **Guidelines**

Follow these guidelines before operating any jobsite equipment:

- Complete proper training and read operator's manual before using equipment.
- Classify jobsite based on its hazards and use correct tools and machinery, safety equipment, and work methods for jobsite.
- Mark jobsite clearly and keep spectators away.
- Wear personal protective equipment.
- Review jobsite hazards, safety and emergency procedures, and individual responsibilities with all personnel before work begins.
- Replace missing or damaged safety signs.
- Use equipment carefully. Stop operation and investigate anything that does not look or feel right.
- Contact your equipment dealer if you have any question about operation, maintenance, or equipment use.

## Safety Alert Classifications

These classifications and the icons defined on the following pages work together to alert you to situations which could be harmful to you, jobsite bystanders or your equipment. When you see these words and icons in the book or on the unit, carefully read and follow all instructions. **YOUR SAFETY IS AT STAKE.**



Watch for the three safety alert levels: **DANGER**, **WARNING** and **CAUTION**. Learn what each level means.

 **DANGER** indicates an imminently hazardous situation which, if not avoided, will result in death or serious injury.

 **WARNING** indicates a potentially hazardous situation which, if not avoided, could result in death or serious injury.

 **CAUTION** indicates a potentially hazardous situation which, if not avoided, may result in minor or moderate injury.

Watch for two other words: **NOTICE** and **IMPORTANT**.

**NOTICE** can keep you from doing something that might damage the unit or someone's property. It can also alert you against unsafe practices.

**IMPORTANT** can help you do a better job or make your job easier in some way.

## Safety Alerts

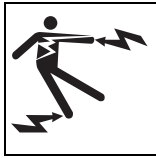
**⚠ DANGER**

Electric shock. Contacting electric lines will cause death or serious injury. Know location of lines and stay away.

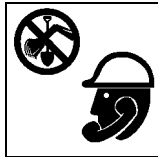
**⚠ WARNING**

Jobsite hazards could cause death or serious injury. Use correct equipment and work methods. Use and maintain proper safety equipment.

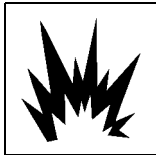
**⚠ WARNING**

Explosion possible. Serious injury or equipment damage could occur. Follow directions carefully.

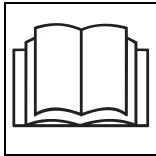
**⚠ WARNING**

Incorrect procedures could result in death, injury, or property damage. Learn to use equipment correctly.

**⚠ WARNING**

Moving traffic - hazardous situation. Death or serious injury could result. Avoid moving vehicles, wear high visibility clothing, post appropriate warning signs.

---

# Controls

## Chapter Contents

**Receiver . . . . . 14**

- Controls . . . . .14
- Displays . . . . .16
- Menu . . . . .19

**Transmitter . . . . . 23**



# Receiver

## Controls

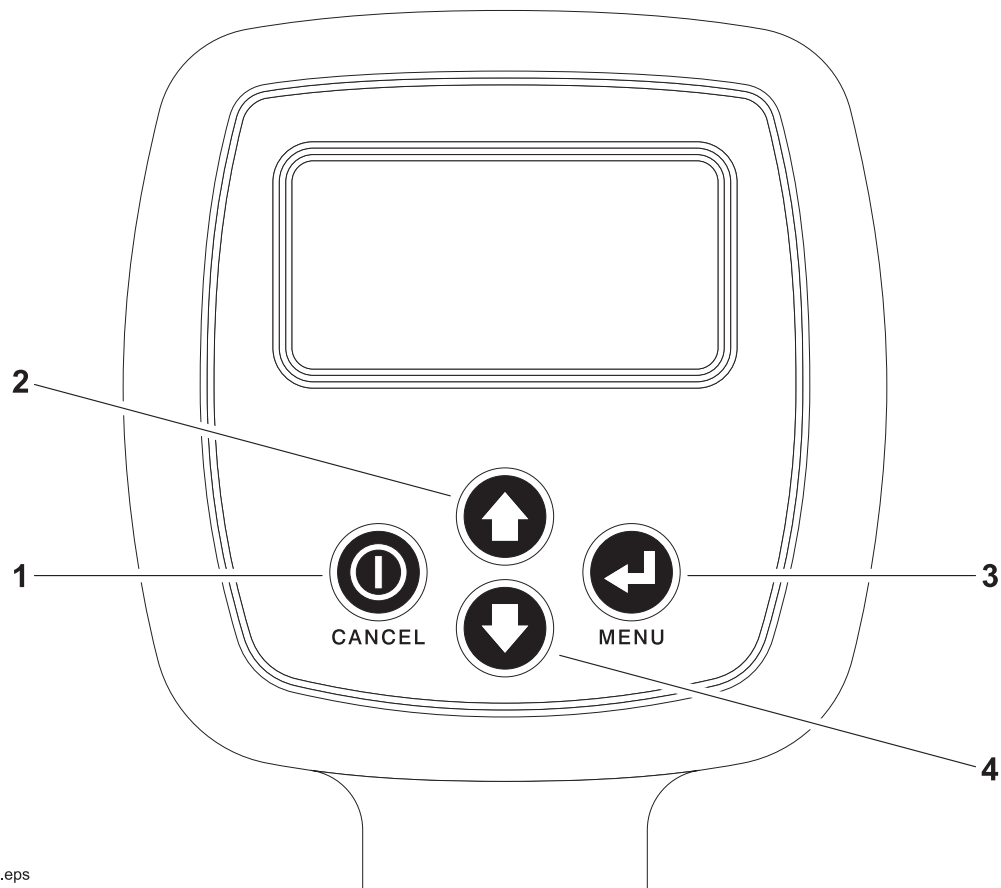

e07om003a.eps

- 1. On-off/Cancel
- 2. Up arrow

- 3. Select/Menu
- 4. Down arrow

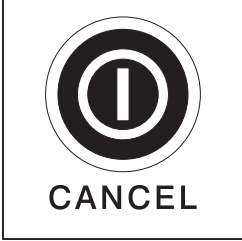
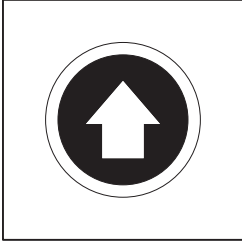
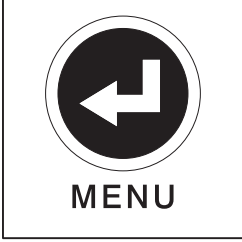
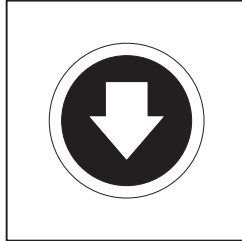
Item	Description	Notes
<p><b>1. On-Off/Cancel</b></p>  <p>e07om004a.eps</p>	<p>To turn on, press.</p> <p>To turn off, press again.</p> <p>To cancel current action in menu mode, press.</p>	
<p><b>2. Up Arrow</b></p>  <p>e07om006a.eps</p>	<p>To increase gain, press.</p> <p>To scroll up menu options in menu mode, press.</p>	
<p><b>3. Select/Menu</b></p>  <p>e07om005a.eps</p>	<p>To access the menu screen, press.</p> <p>To select highlighted menu option, press again.</p>	
<p><b>4. Down Arrow</b></p>  <p>e07om007a.eps</p>	<p>To decrease gain, press.</p> <p>To scroll down menu options in menu mode, press.</p>	





## Displays

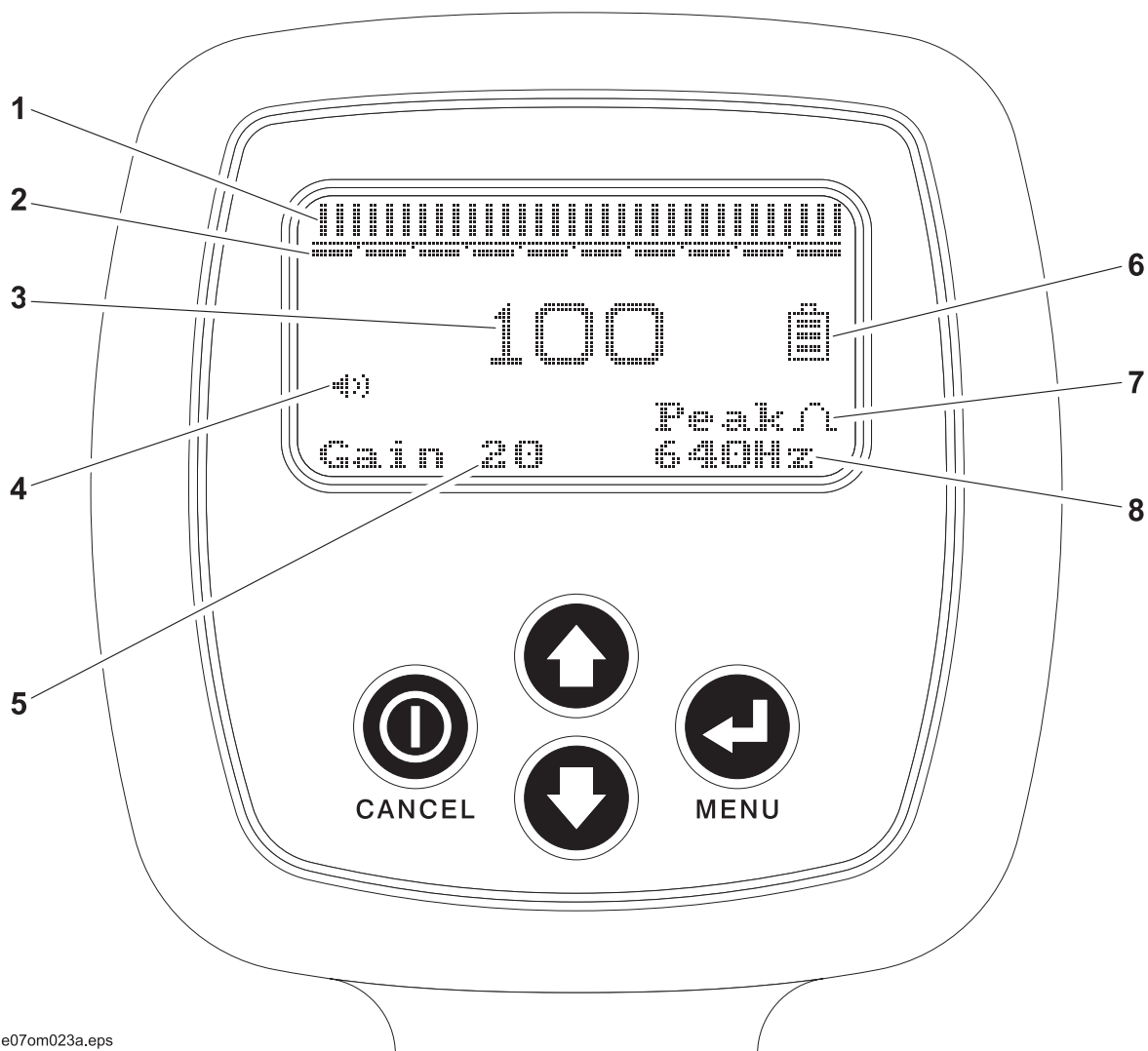

e07om023a.eps

- |                    |                  |
|--------------------|------------------|
| 1. Signal bar      | 5. Gain level    |
| 2. Gain bar        | 6. Battery level |
| 3. Signal strength | 7. Antenna mode  |
| 4. Volume level    | 8. Frequency     |

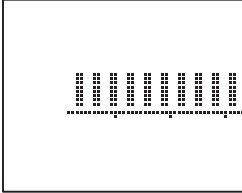
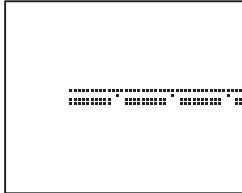
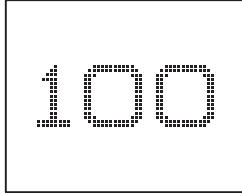
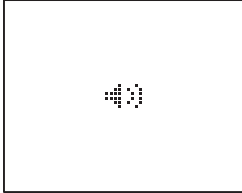
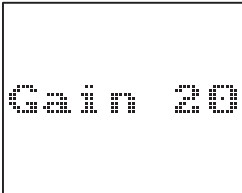
Item	Description	Notes
<p><b>1. Signal Bar</b></p>  <p>e07om059a.eps</p>	<p>Graphically represents the signal strength levels.</p>	
<p><b>2. Gain Bar</b></p>  <p>e07om060a.eps</p>	<p>Graphically represents the gain.</p> <p>Gain increases to the right.</p>	
<p><b>3. Signal Strength</b></p>  <p>e07om061a.eps</p>	<p>Numerically represents the one-hundred and one (0-100) signal strength levels.</p>	
<p><b>4. Volume Level</b></p>  <p>e07om062a.eps</p>	<p>Indicates volume is turned to an on position.</p>	
<p><b>5. Gain Level</b></p>  <p>e07om063a.eps</p>	<p>Numerically represents twenty-one (0-20) gain levels.</p>	

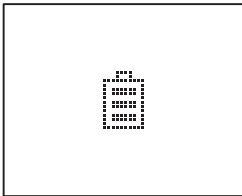
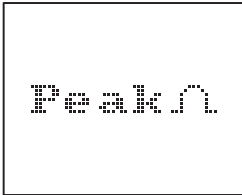
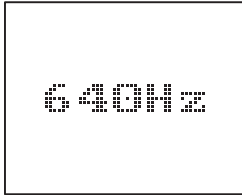

Item	Description	Notes
<p><b>6. Battery Level</b></p>  <p>e07om064a.eps</p>	<p>Indicates battery level. Three segments indicates full battery level. One segment indicates low level. No segments indicates that batteries should be changed soon.</p>	
<p><b>7. Antenna Mode</b></p>  <p>e07om065a.eps</p>	<p>Indicates factory antenna configuration. Unit is factory configured in peak or null mode.</p>	
<p><b>8. Frequency</b></p>  <p>e07om066a.eps</p>	<p>Indicates frequency setting.</p>	

## Menu

### Select Frequency (Peak Units)

**IMPORTANT:** Receiver units configured to operate in null mode do not have a frequency menu.

The 150R has three available active and two passive frequencies: 640Hz, 30kHz, or 83kHz, 60S, and 60P.

1. Press **Menu** to select frequency setting.
2. Press **Menu** to select the Frequency option.
3. Use **Up Arrow** or **Down Arrow** to highlight the desired frequency.

**IMPORTANT:** 150R units will be factory configured with either 640Hz, 30kHz or 83kHz.

4. Press **Menu** to return to display.



e07om025a.eps

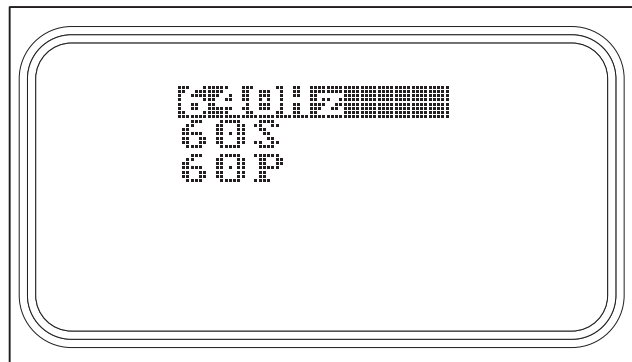

e07om026a.eps

### Adjust Volume

Receiver has four volume levels: off, low, medium and high.

1. Press **Menu** to select volume setting.
2. Press **Down Arrow** to highlight volume option.
3. Press **Menu** to select the volume menu.

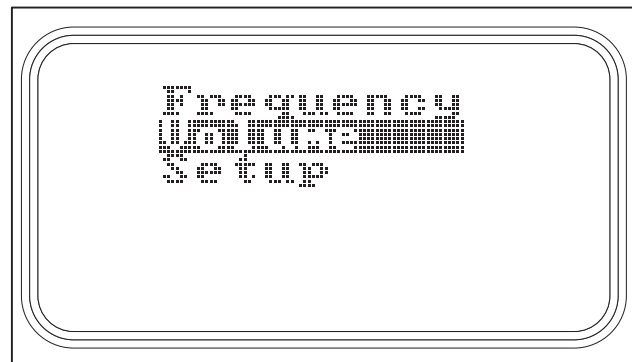

e07om029a.eps

4. Use **Up Arrow** or **Down Arrow** to adjust the volume to the desired level.
5. Press **Menu** to return to display.

**IMPORTANT:** Maintain a lower volume to conserve battery life.



e07om030a.eps

### Setup Menu

Setup Menu allows operator to select audio mode, adjust contrast and perform a self test.

1. Press **Menu** to enter setup menu.
2. Press **Down Arrow** to highlight setup.
3. Press **Menu** to select **Setup**.

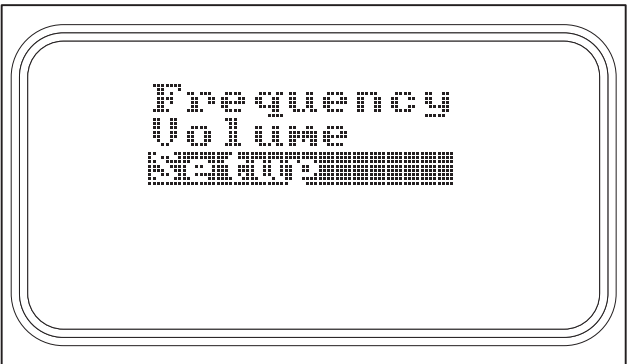

e07om031a.eps

### Select Audio Mode

Receiver has two audio modes: single tone (volume increases with signal strength) and tone shift (pitch increases with signal strength).

1. Enter Setup Menu, see "Setup Menu" on page 20.
2. Select Audio Mode menu, press **Menu**.
3. Use the **Up Arrow** or the **Down Arrow** to select the desired audio mode.
4. Press **Menu** to return to display.



e07om032a.eps

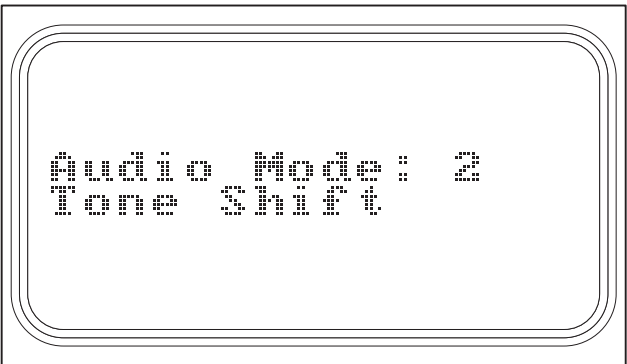

e07om033a.eps

## Adjust Contrast

Receiver has twenty-five levels of contrast from light to dark.

1. Enter Setup Menu, See "Setup Menu" on page 20.
2. Press **Down Arrow** to highlight Contrast.
3. Press **Menu** to enter Contrast menu.
4. Use **Up Arrow** or **Down Arrow** to adjust contrast to desired level.
5. Press **Menu** to return to display.

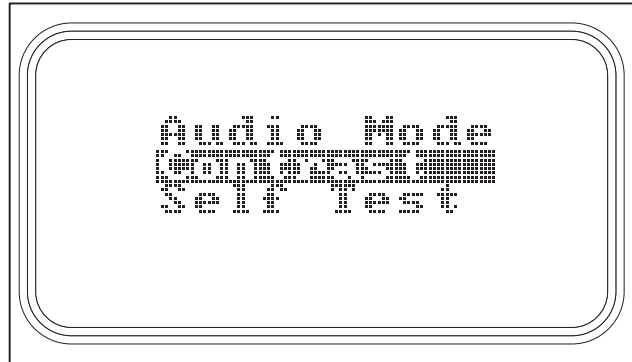

e07om035a.eps

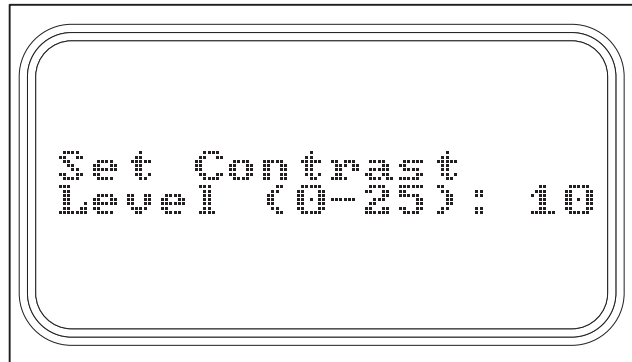

e07om036a.eps

## Perform Self Test

Receiver performs self test to detect errors.

1. Enter Setup Menu, see "Setup Menu" on page 20.
2. Press **Down Arrow** to highlight Self Test.
3. Press **Menu** to perform a self test.
4. Turn off all beacons and transmitters.
5. Press any key to begin test.



e070m037a.eps

**IMPORTANT:** Do not move receiver during test.

6. Receiver will display self test results.
  - If receiver finds no errors, it will display "All channels passed. Press any key . . . ."
  - If receiver detects errors the operator can resolve, see "Receiver Error Messages" on page 47.

# Transmitter

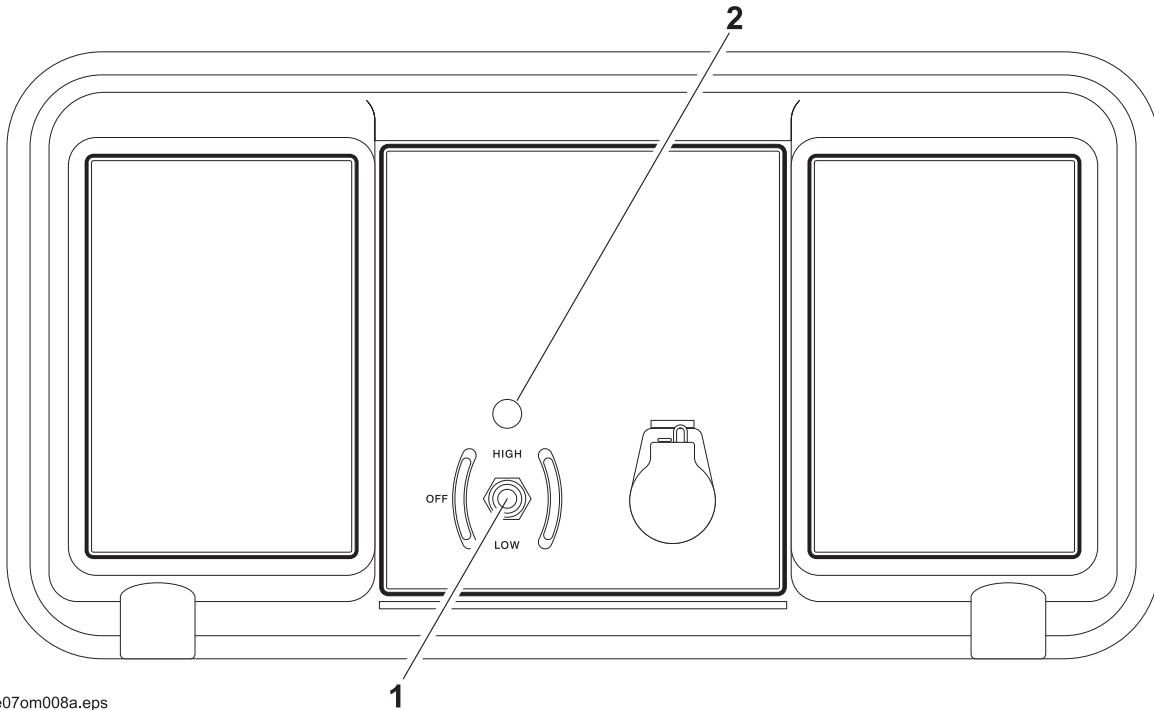

e07om008a.eps

1. Power

2. Battery level indicator

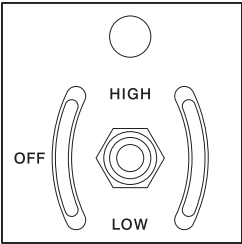
Item	Description	Notes
<p><b>1. Power</b></p>  <p>e07om045a.eps</p>	<p>To deliver high power, move switch up.</p> <p>To deliver low power, move switch down.</p> <p>To turn off, move switch to center.</p>	

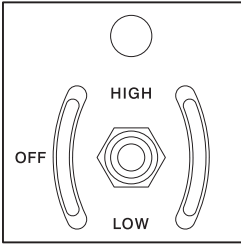

Item	Description	Notes
<p><b>2. Battery Level Indicator</b></p>  <p>e070m045a.eps</p>	<p>Indicates battery level when unit is in high or low position.</p> <ul style="list-style-type: none"> <li>• Solid light indicates sufficient battery level.</li> <li>• Flashing light during operation indicates low battery level.</li> <li>• Flashing light at startup indicates battery level is low or one battery is installed backwards.</li> </ul>	<p><b>IMPORTANT:</b></p> <ul style="list-style-type: none"> <li>• The unit will continue transmitting a signal if green light flashes while in operation but power will decrease.</li> <li>• The unit will not transmit a signal if green light is flashing when unit is turned on.</li> </ul>

# Locate

## Chapter Contents

**Active . . . . . 26**

- Setup . . . . . 26
- Technique . . . . . 29
- Special Situations . . . . . 31

**Passive . . . . . 32**

- Setup . . . . . 32
- Technique . . . . . 32
- Special Situations . . . . . 36

**Beacon . . . . . 37**

- Setup . . . . . 37
- Technique . . . . . 37



## Active Location

### Setup

Follow setup procedures for the type of locating you will be doing: direct connection, induction clamp, or broadcast induction. Always check receiver battery level at startup. See "Controls" on page 13.

### Direct Connection

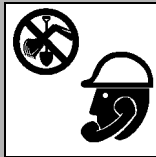

#### **WARNING**

Jobsite hazards could cause death or serious injury. Use correct equipment and work methods. Use and maintain proper safety equipment.

**NOTICE:** Electric shock or equipment damage can result if transmitter is connected to live cable. Contact qualified utility personnel and follow all local standards and restrictions for disconnecting and grounding lines.

To set up transmitter for direct connection:

1. Drive ground stake (4).
2. Plug cable into transmitter (2).
3. Hook black lead to ground stake (3).
4. Hook red lead to line (1).
5. Turn on transmitter.
6. Check battery level indicator.

#### **NOTICE:**

- Do not unplug direct connect cable from transmitter when connected to line. Removing cable will cause an arc and could damage equipment or cause injury.
- Turn off transmitter when connecting or moving ground stake.

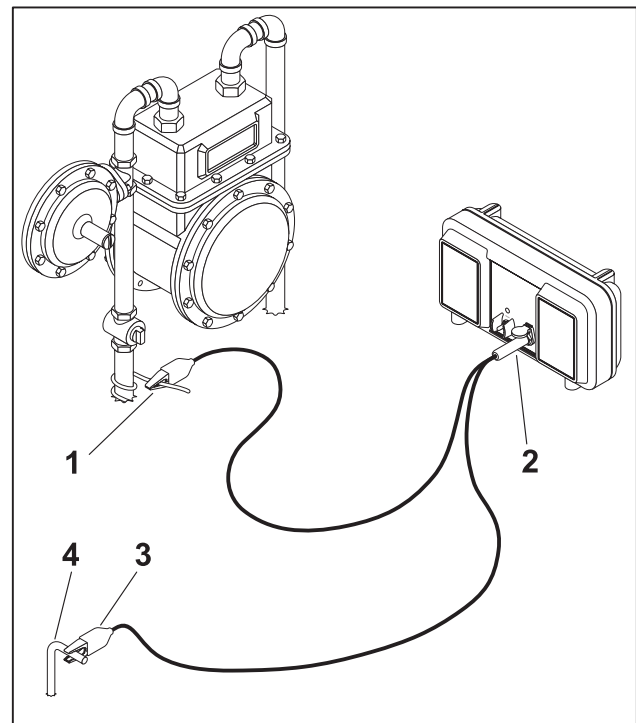

e07om010a.eps

## Induction Clamp



**WARNING**

Jobsite hazards could cause death or serious injury. Use correct equipment and work methods. Use and maintain proper safety equipment.

**NOTICE:** Electric shock or equipment damage can result if transmitter is connected to live cable. Contact qualified utility personnel and follow all local standards and restrictions for disconnecting and grounding lines.

To set up transmitter for use with induction clamp:

1. Plug cable into transmitter (1).
2. Place clamp around line (2).
3. Turn on transmitter.
4. Check battery level indicator.

**NOTICE:** Do not unplug induction cable from transmitter (1) when connected to line (2). Removing cable will cause an arc and could damage equipment or cause injury.

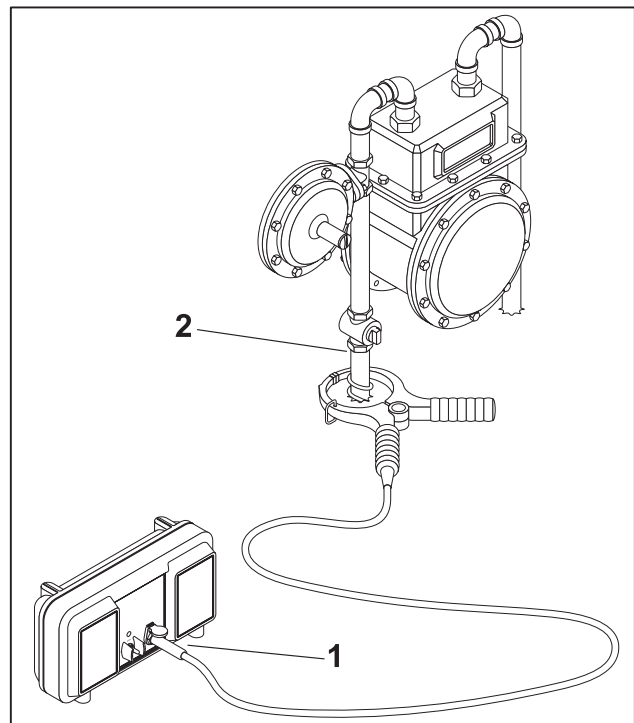

e07om047a.eps



## Broadcast Induction

To set up transmitter for broadcast induction:

1. Remove cable, stake, clamp and any other metal objects from transmitter.
2. Place transmitter parallel to and directly above suspected line as shown.

**Note:** Transmitter must be parallel to object, as shown, in order to produce the best signal.

3. Turn on transmitter.
4. Check battery level indicator.

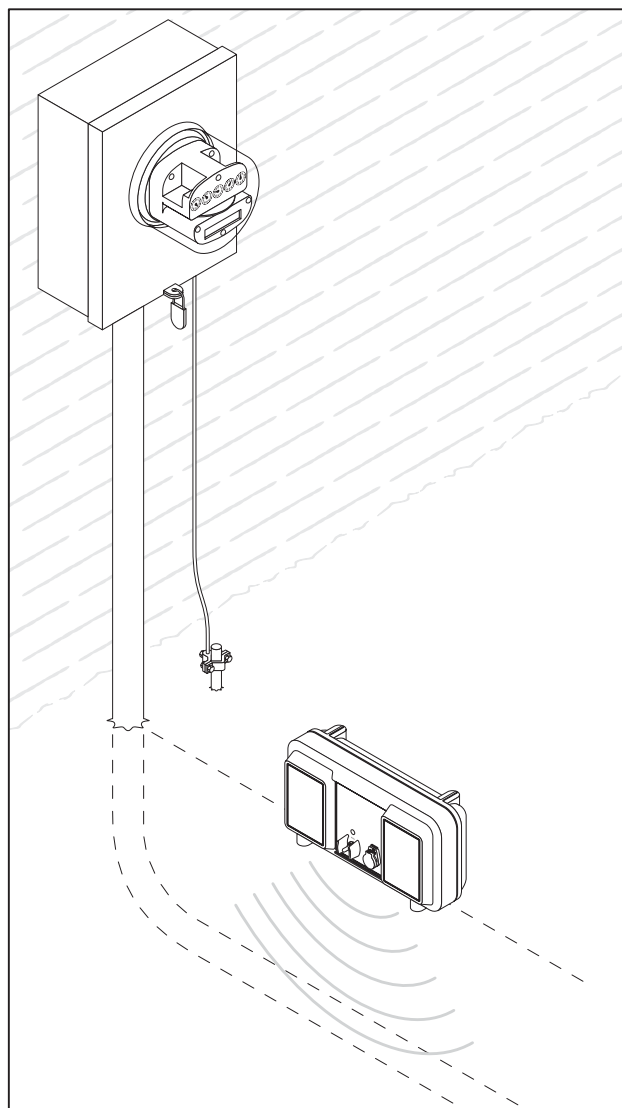

e07om012a.eps

## Technique

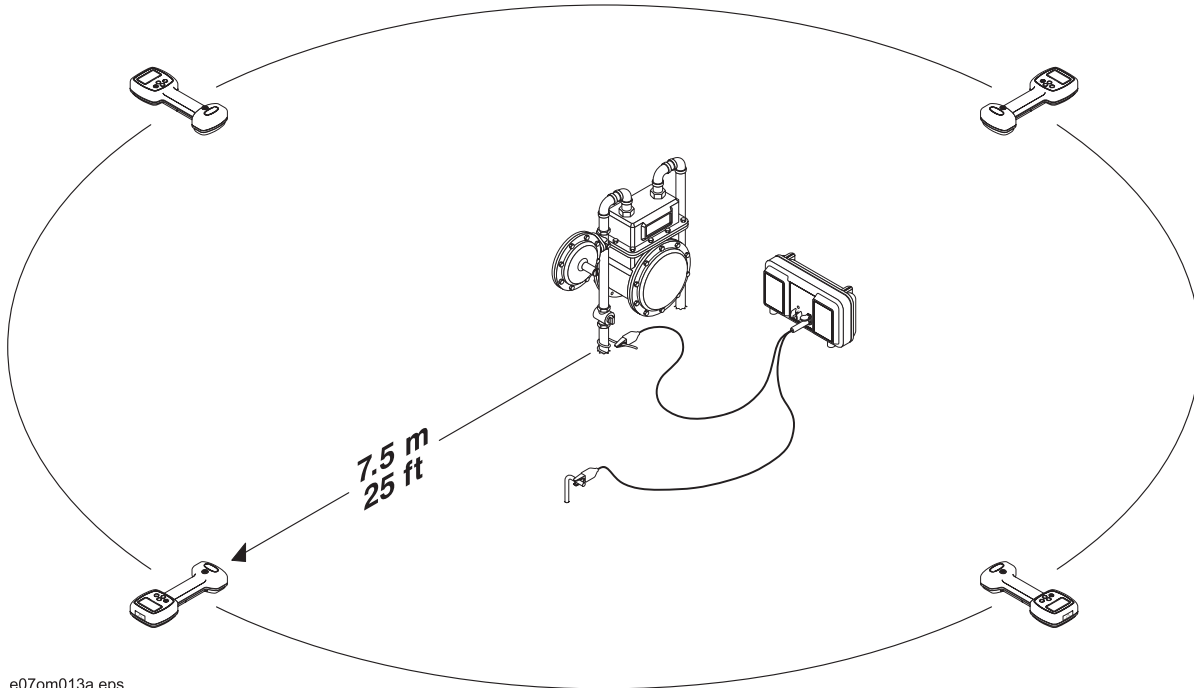

e07om013a.eps

**IMPORTANT:** Follow steps 1-3 for all types of active location. For reference, the illustration above shows direct connection method. If using broadcast induction, ensure that transmitter is in line with and above suspected line, as shown on previous page.

1. Walk in an arc approximately 25' (7.5 m) around utility to be located.
2. Hold the receiver so that the handle points toward the transmitter, as shown.
3. Identify location of line by finding the spot with the best signal response.



4. Rotate the receiver to determine which direction the line runs.

**IMPORTANT:** Receiver indicates the best signal when the handle lines up with the target line.

5. Trace the line and mark with appropriate flags or paint.

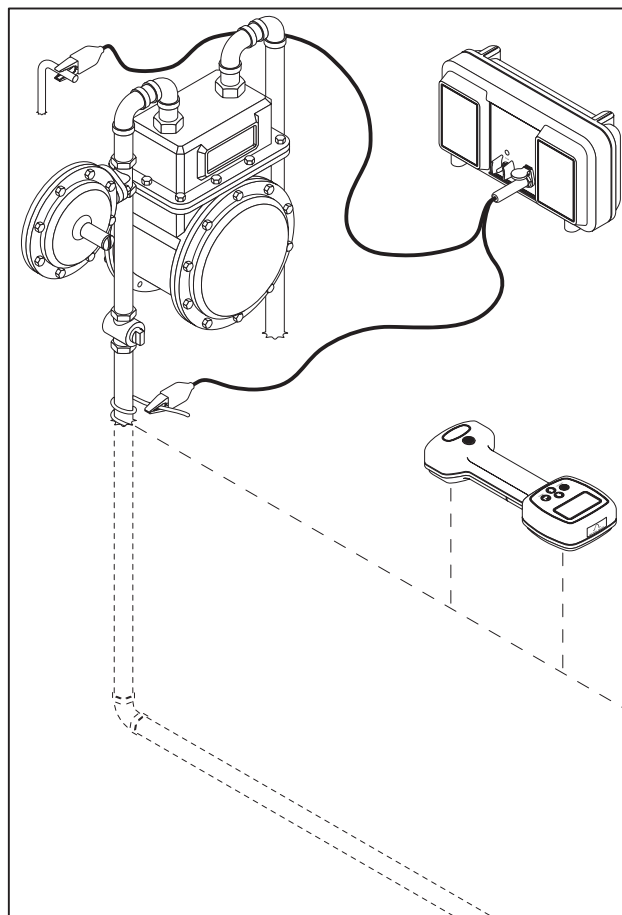

e070m014a.eps

## Mark the Line

Sweep, focus, and trace all detected signals in the area. Mark line paths with colored paint or flags. See the chart below for standard color markings for line locations.

Utility	Color	Marking Symbol
electric	red	-E-
gas/oil	yellow	-G-
communications	orange	-TEL- or -TV-
water	blue	-W-
sewer	green	-S-



## Special Situations

Situation	What to try
Signal is lost.	Walk in a circle to detect a tee or bend in the line.
Signal varies from low to high and is unstable.	Mark as a hand-dig area.
You are near a power line and are receiving interference.	Sweep the area in 60P mode. If receiver gives a strong signal response, a power line is interfering with transmitter signal.
Receiver does not function properly.	Receiver gain could be set too high or low. Lower or raise gain to locate the line. See "Controls" on page 13.
Target line has connections to other lines.	Disconnect target line from other lines or use direct connect or induction clamp to focus signal on target line.
Signal is transferring to other lines.	<ul style="list-style-type: none"> <li>• Lower the power level.</li> <li>• Use direct connection, if possible, or use induction clamp.</li> <li>• Move the ground stake away from the target line and away from other buried lines.</li> <li>• Apply signal at the point where the target line is farthest from the other lines.</li> </ul>



## Passive Location

### Setup

Follow setup procedures for the type of locating you will be doing. Always check receiver battery level at startup. See "Controls" on page 13.

**NOTICE:** Lines with no A/C current flowing through them are hard to detect and may be hazardous because they may still have voltage potential. To locate, turn on an appliance to cause current to flow and use active search methods.

Use 60P frequency to locate primary lines from source to transformer. Use 60S frequency to locate secondary lines from transformer to meter.

### Technique

#### Survey the Site

Make a visual check of the site for signs of buried lines such as:

- recent trenching
- buried line markers
- overhead lines that run down pole and underground
- gas meters
- valve sights
- drains or manhole covers

### Sweep the Site

Search the site by walking a grid pattern while holding receiver close to the ground.

**NOTICE:** Keep receiver level.

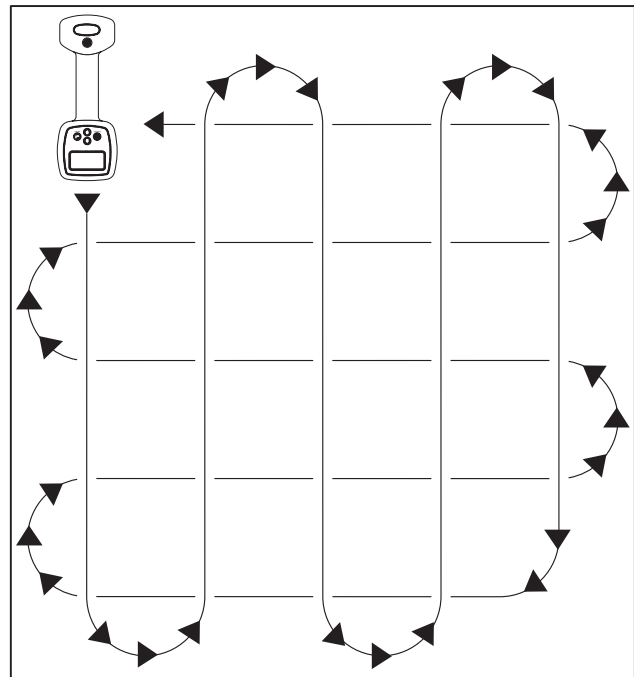

e07om016a.eps



### Focus the Signal

Move receiver over detected signal to find best signal response. If using a peak antenna mode, rotate receiver until signal is best. Best signal indicates line direction.

**NOTICE:** Keep receiver level.

## Antenna Mode Configuration

All 150R receiver units can locate in either peak or null mode.

Rotate receiver 90° to locate using other antenna mode. When rotated 90°, a peak configured receiver will function as a null receiver or a null configured receiver will function as a peak receiver.

**IMPORTANT:** The operator will not be able to view display in other antenna mode.

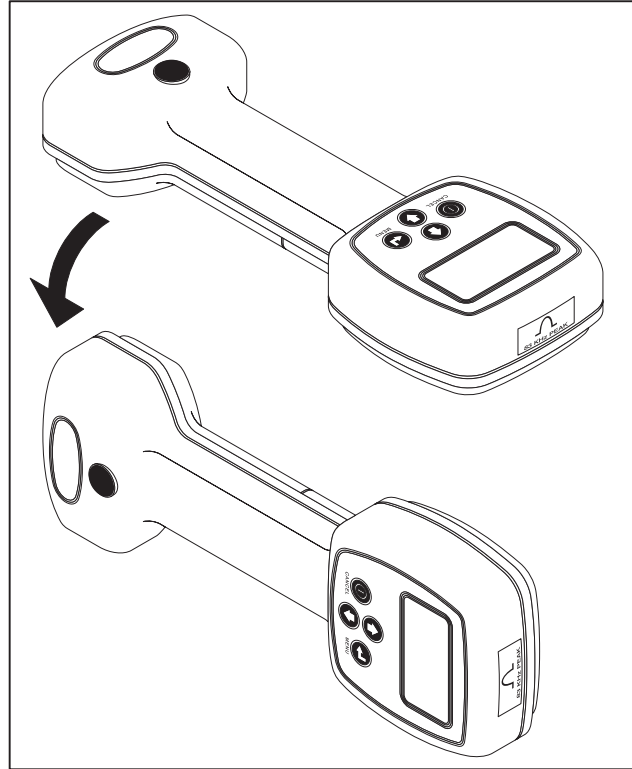

e07om043a.eps

### Trace the Line

Walk along the suspected path while moving the receiver from side to side across the area.

**IMPORTANT:** Keep receiver handle parallel to the suspected line path.

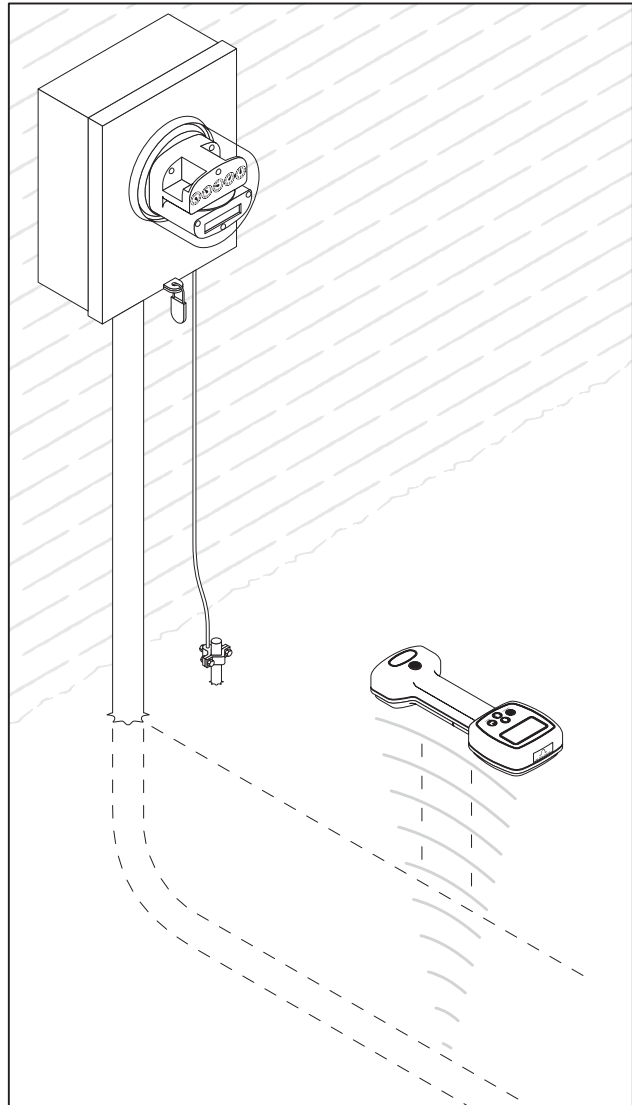

e07om053a.eps



---

**Mark the Line**

Sweep, focus, and trace all detected signals in the area. Mark line paths with colored paint or flags. See the chart below for standard color markings for line locations.

Utility	Color	Marking Symbol
electric	red	-E-

**Special Situations**

Situation	What to try
Signal is lost.	Walk in a circle to detect a tee or bend in the line.
Signal varies from low to high and is unstable.	Mark as a hand-dig area.
Receiver does not function properly.	Receiver gain could be set too high or low. Lower or raise gain to locate the line. See "Controls" on page 13.

## Beacon Location

Trace metallic or non-metallic pipes or conduits by locating and following a beacon signal.

**IMPORTANT:** Large metal objects and other signals (such as railroad signals or overhead power lines) will distort signal.

### Setup

To set up for beacon location:

1. Follow instructions for installing beacon battery. See "Beacon Unit" on page 46.
2. Turn on receiver to ensure that beacon is functioning properly.
3. Attach beacon to plumber's snake or flex rod.



### Technique

1. Turn on receiver.
2. Set signal frequency.
3. Place beacon into the pipe and move it down the pipe.
4. To locate beacon, circle over its approximate location in the pipe.
5. To identify the location of beacon, find the spot with the strongest signal response.
6. Rotate the receiver to determine which direction beacon runs.

**IMPORTANT:** Receiver indicates the best signal when handle is perpendicular to the beacon.

7. Continue to track beacon. Mark pipe location with paint.

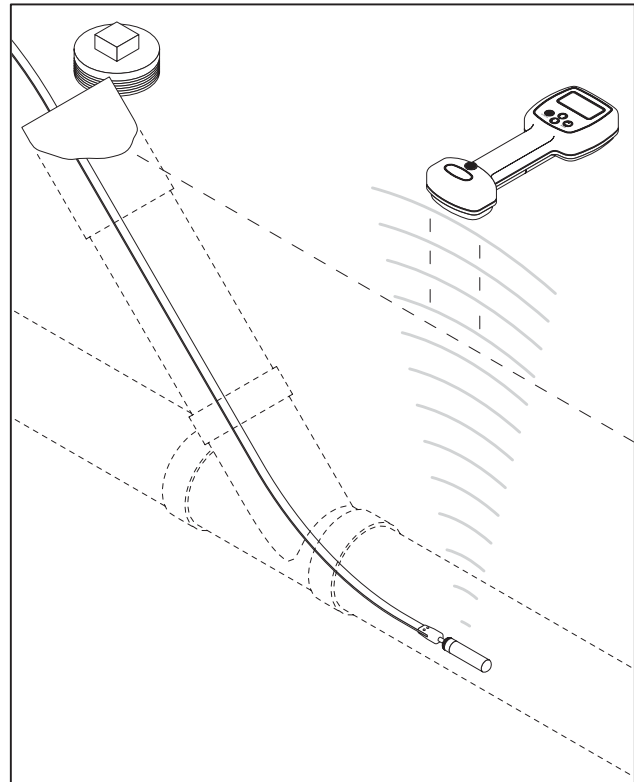

e07om015a.eps



---

# Locating Concepts

## Chapter Contents

**Signal Type . . . . . 40**

- Active . . . . .40
- Beacon . . . . .40
- Passive . . . . .40

**Antenna Configuration . . . . . 41**

- Peak . . . . .41
- Null . . . . .41
- Advantages/Disadvantages . . . . .41

**Common Signal Problems . . . . . 42**

- Shadows . . . . .42
- False Signals. . . . .42
- Secondary (Ghost) Signals. . . . .42





## Signal Type

The 150R can detect three types of signals:

- Active signals that are placed on a target line with a transmitter.
- An active signal from a beacon.
- Passive signals that reside on the target line.

### Active

There are three ways to place active signals on a target line with a transmitter:

- Direct connection (preferred method) requires a connection to be made directly onto target line.
- Induction requires placing an optional induction clamp around target line.
- Broadcast method uses a built-in antenna to broadcast a signal onto lines near the transmitter.

### Beacon

Beacon signals allow metallic and non-metallic pipe or conduit tracing.

### Passive

Power line signals can be detected passively without a transmitter.

## Receiver Gain Level

The receiver gain setting controls the sensitivity to the signal.

Action	Result	Effect
increasing gain	more sensitive to signal	allows location farther away from signal source
decreasing gain	less sensitive to signal	stabilizes signal

## Antenna Configuration

The 150R receiver is available with one of two antenna configurations: peak or null.

### Peak



Uses a horizontal antenna to detect signal. Response is highest at strongest signal.

### Null

Uses a vertical antenna to detect signal. Search width is narrower than peak. Response is lowest when receiver is over the line.

### Advantages/Disadvantages

Read the descriptions below and determine the antenna configuration that best fits your job.

Antenna	Antenna	Advantages	Disadvantages
	peak	more range	less precise
	null	sharp response	easily distorted in congested areas



## Common Signal Problems

Distortions in the electromagnetic field around a line can affect location accuracy. Tees, bends, parallel lines, crossing lines, or large metallic objects can distort signals.

**IMPORTANT:** If target depth and location are critical, confirm by hand-digging or vacuum excavation.

Learn to recognize the following kinds of distortion:

### Shadows

Shadows, also called blind spots, often happen when a metallic object partially obstructs the signal, or a signal from a parallel line interferes with target signal.

### False Signals

False signals describe situations where the receiver indicates a line location where there is no line. False signals often happen when a line tees or bends, runs parallel to the target line, or crosses the target line.

**IMPORTANT:** Generally, the receiver shows less distortion in peak antenna configuration.

### Secondary (Ghost) Signals

A typical beacon signal pattern shows a main signal and two weaker secondary signals. Identify beacon location at the main signal. Familiarity with beacon signal patterns will lessen the effect of ghost signals.

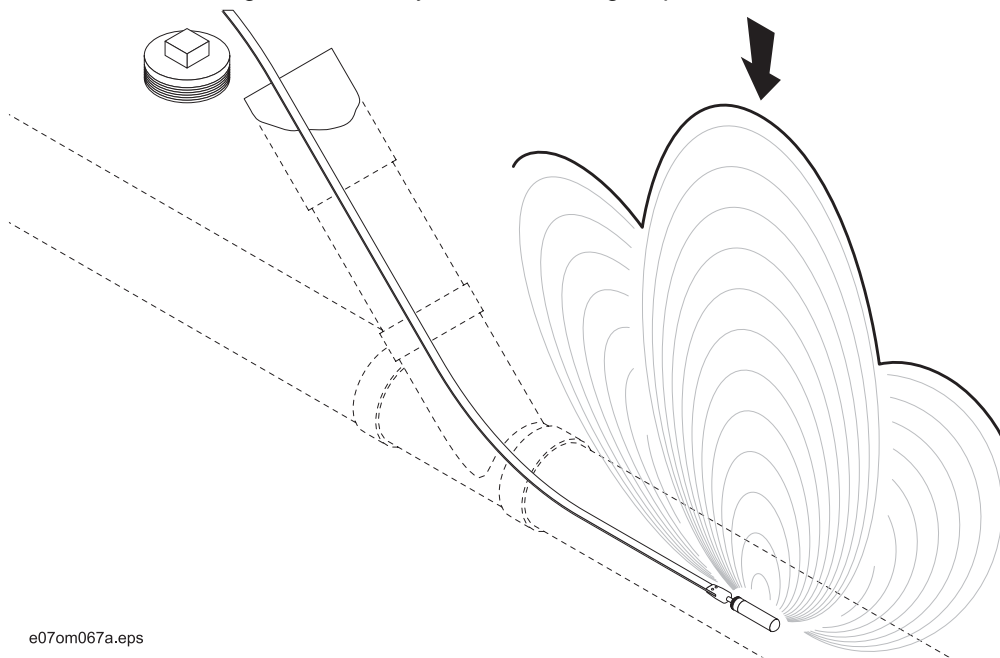

e07om067a.eps

---

# Service

## Chapter Contents

General Care . . . . .	44
As Needed . . . . .	44
Self Test Error Messages . . . . .	47
Receiver Error Messages . . . . .	47



## General Care

Under normal operating conditions, receiver needs only minor maintenance. Following these care instructions can ensure longer equipment life:

- Do not drop the equipment.
- Do not expose the equipment to high heat (such as in the rear window of a vehicle).
- Clean equipment with a damp cloth and mild soap. Never use scouring powder.
- Do not immerse in any liquid.
- Inspect housing daily for cracks or other damage. If housing is damaged, contact your equipment dealer for replacement.
- Do not mix new and used batteries.

## As Needed

Location	Task	Notes
Receiver Unit	Change batteries	2 "C" batteries
Transmitter Unit	Change batteries	6 "C" batteries
Beacon Unit(s)	Change battery	1 "N" battery

## Receiver Unit

### Change Batteries

Use two C-cell alkaline batteries in receiver.

1. Remove battery cover.
2. Insert batteries as shown.
3. Install and tighten battery cover.
4. Check operation.

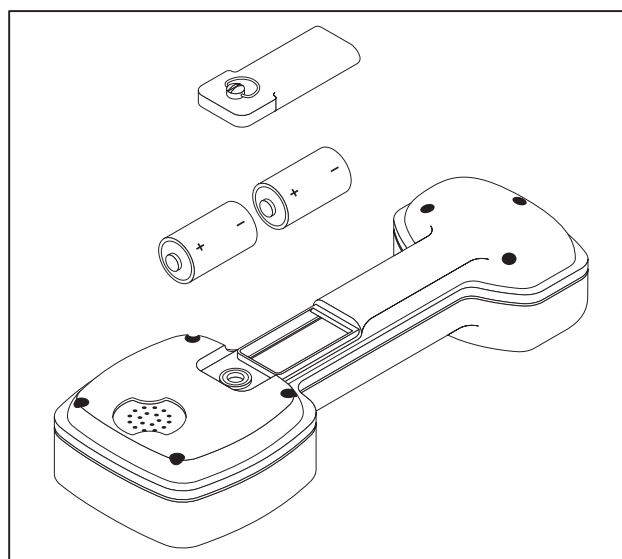

e07om018a.eps

## Transmitter Unit

### Change Batteries

Use six C-cell alkaline batteries in transmitter.

1. Open battery cover.
2. Insert batteries as shown.

**IMPORTANT:** Do not mix new and used batteries.

3. Close and tighten battery cover.
4. Check operation. If battery light is flashing when unit is turned on, then one battery is incorrectly installed or batteries are weak.

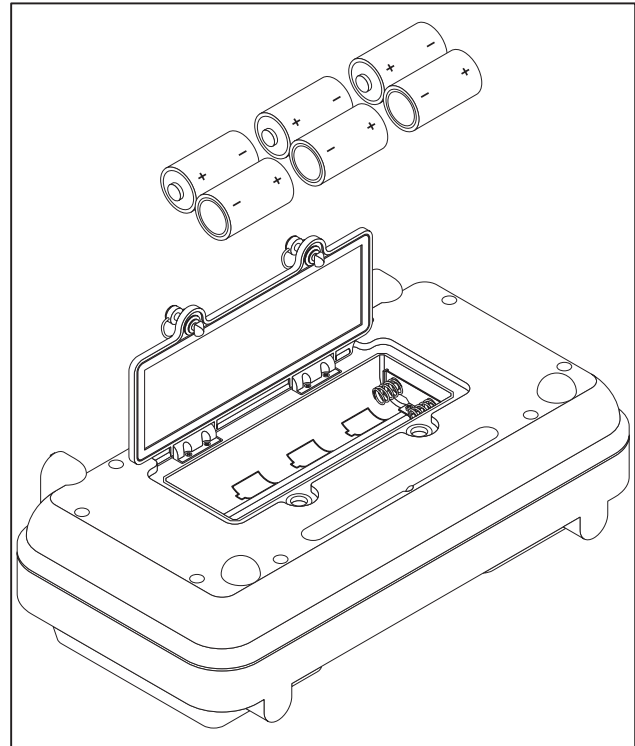

e07om017a.eps



## Beacon Unit

### Change Battery

Use one N-cell alkaline battery in beacon.

1. Open battery cap.
2. Insert battery as shown.
3. Tighten battery cap.
4. Check operation.

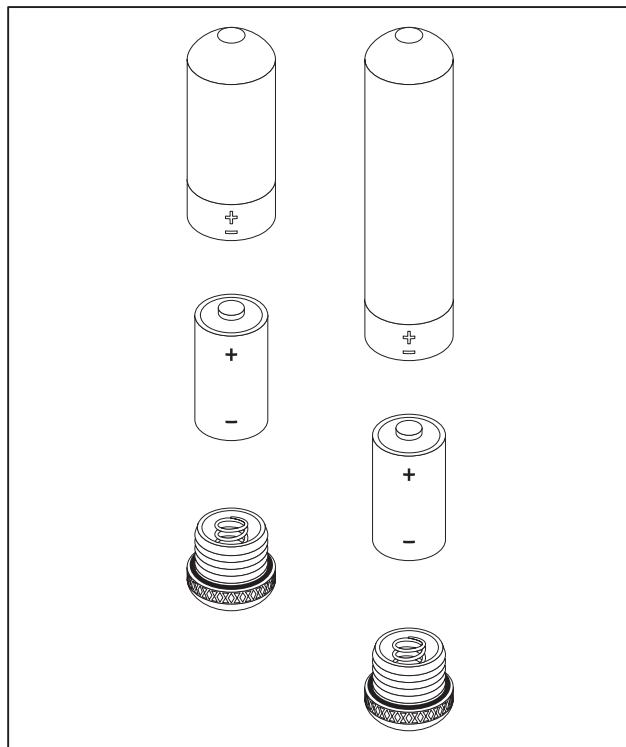

e07om019a.eps

## Self Test Error Messages

A Receiver self test may return an error message for four reasons: low sensitivity, a failed channel, noise present, or gain test failure.

### Low Sensitivity

A low sensitivity message will always appear together with a “noise” screen. This could indicate a problem with the antenna, or it could simply be the result of attempting to test in a noisy environment. Try the test again later, preferably in a different location. If this problem persists, contact Product Support. A unit in this condition will still be usable in many cases, but performance will not be optimal.

### Noise Present

A noise present message appears with each low sensitivity message. If noise present appears by itself, the signal received in the test was higher than expected. This is usually the result of noise in the area and may not indicate a problem. The most likely cause of this message is a transmitter or beacon nearby. Ensure that all beacons and transmitters are turned off and conduct the test again.

### Gain Test Failed

A failed gain test message indicates a specific type of hardware failure. Like the other tests, it could result if there is excessive noise in the area. If the message persists, contact Product Support.



### Channel Failed

A failed channel test message indicates that no signal was received by that channel during the test. This almost always indicates a hardware problem. Contact Product Support.

## Receiver Error Messages

### Shut Down Failed

A failed shut down message indicates a hardware problem. Remove batteries and contact Product Support.





# Specifications

## 150 Receiver

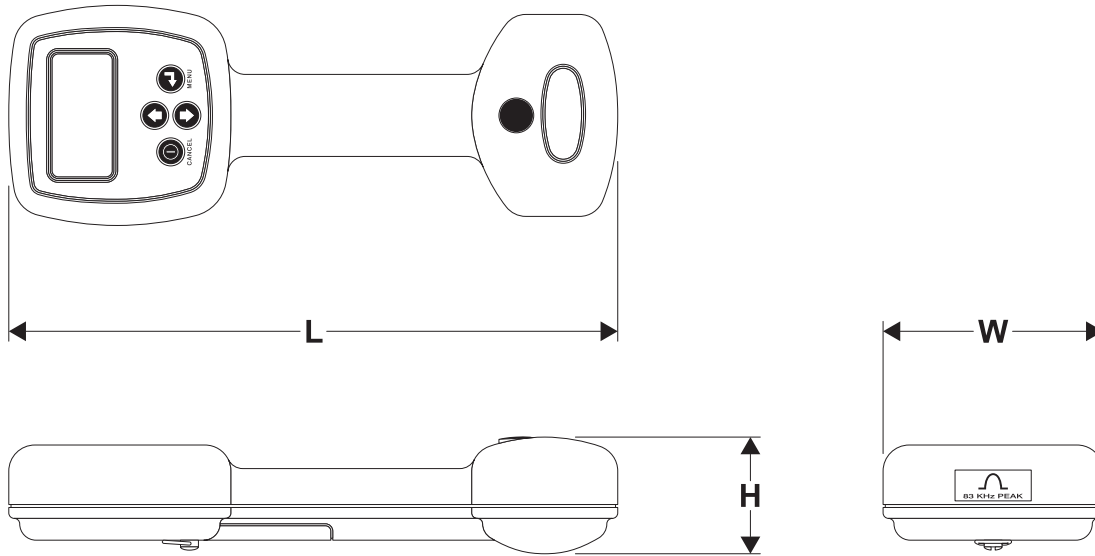

e07om002a.eps

Dimensions		U.S.	Metric
H	Height	2.37"	6.02 cm
L	Length	12"	30.48 cm
W	Width	4.37"	11.01 cm
	Weight	2 lb	0.91 kg



# 150 Transmitter

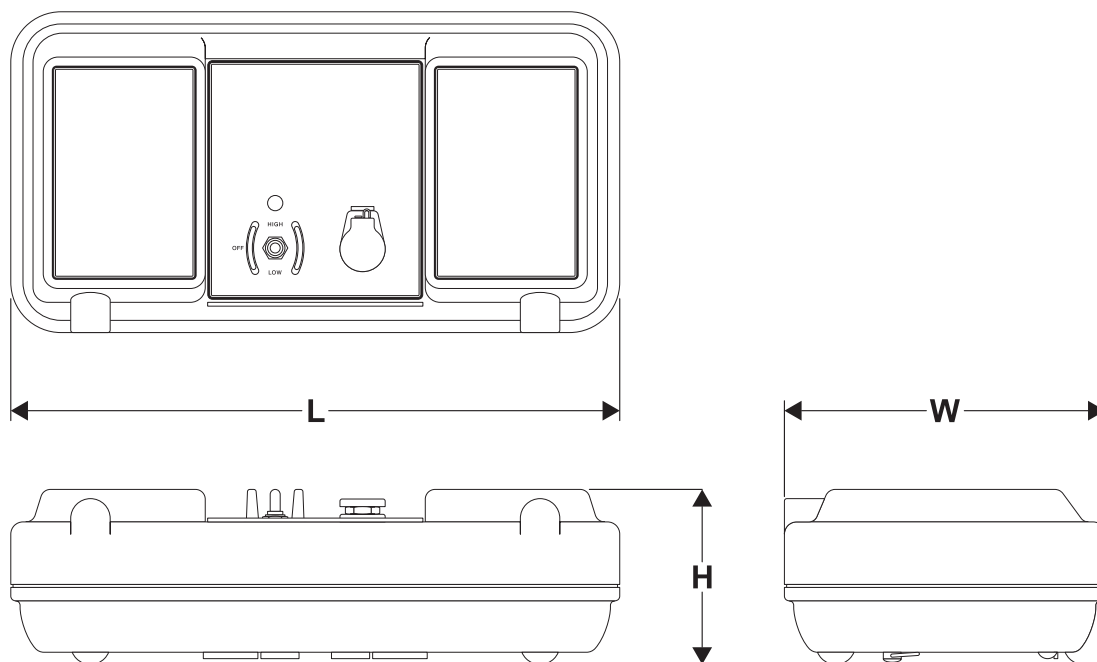

e07om001a.eps

Dimensions		U.S.	Metric
H	Height	3.43"	8.71 cm
L	Length	12"	30.48 cm
W	Width	6.25"	15.88 cm
	Weight	3 lb	1.36 kg

# 150 Beacons

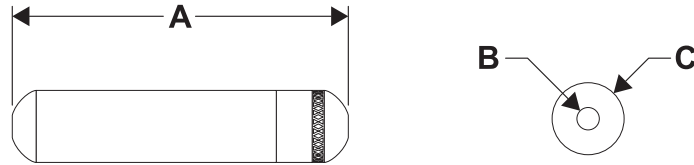

e07om044a.eps

Dimensions		U.S.	Metric
<b>640 WS</b>			
A	Length	2.2"	5.6 cm
B	Flex rod	1/4-20UNC	
C	Diameter	0.75"	1.9 cm
	Weight	1.9 oz	52.73 g
<b>30K Conduit</b>			
A	Length	3.6"	1.9 cm
B	Flex Rod	1/4-20UNC	
C	Diameter	0.75"	9.14 cm
	Weight	2.3 oz	65.2 g
<b>640 Conduit</b>			
A	Length	3.6"	1.9 cm
B	Flex Rod	1/4-20UNC	
C	Diameter	0.75"	9.14 cm
	Weight	2.3 oz	65.20 g



## System Operation

Operation		U.S.	Metric
Operating temperature range		-4° F to 122° F	-20° C to 50° C
Antenna configurations		peak, null	
Audio output		speaker	
Operating modes (some optional)			
	Active line	30kHz, 83kHz	
	Passive line	60Hz (60P), 180Hz (60S)	
	Beacon	640Hz, 30kHz	
Recommended depth ranges*			
	640 beacon in air	12'	3.66 m
	640 beacon in cast iron	6'	1.83 m
	30k beacon in air	12'	3.66 m
	30k active (direct connect)	15'	4.57 m
	83k active (direct connect)	15'	4.57 m

\* Locators are calibrated to these tolerances under ideal test field conditions. Actual operating field conditions may have signal distortions or may contain noise sources which result in depth range that is less than specified.

# Support



## Procedure

Notify your dealer immediately of any malfunction or failure of Subsite equipment.

Always give model, serial number, and approximate date of your equipment purchase. This information should be recorded and placed on file by the owner at the time of purchase.

Return damaged unit to dealer for inspection and warranty consideration if in warranty time frame.

All repairs must be done by an authorized Subsite repair facility. Repairs done elsewhere will void warranty consideration.

## Resources

### Publications

Contact your Subsite dealer for publications and videos covering safety, operation, service, and repair of your equipment.

### Training

For information about on-site, individualized training, contact your Subsite dealer.

# Warranty

## Limited Product Warranty Policy

### Warranty Periods

#### New Product

A twelve-month period starts on the date of delivery to the end user:

receivers, transmitters, radars, fault finders

A six-month period starts on the date of delivery to the end user:

locate beacons

A three-month period starts on the date of delivery to the end user:

accessories: cables, clamps, canoes, bags, and adapters

#### Used Product (Cosmetics)

A three-month warranty starts on the date of delivery to the end user on used and refurbished products sold from Subsite dealers. Used products are non-returnable.

#### Service and Repair

A one-month warranty on **labor** starts on the date the unit is repaired, and a three-month warranty on **parts** starts on the date the unit is repaired for all products.

#### Extended Warranty

The extended warranty may be purchased at the time the equipment is sold or anytime within the original warranty period. The extension is for an additional twelve or twenty-four months, for a total coverage of twenty-four to thirty-six months. Exclusions: All beacons and accessories.

**Details and Exclusions**



- The warranty includes only Subsite products and accessories that are manufactured and distributed by Subsite. The warranty compensates on defects in material or workmanship.
- Defects will be determined through inspection by Subsite or authorized repair centers. Original purchaser must make the defective item available for inspection within 30 days of the date the part fails.
- The warranty is limited to replacement of the defective part. The replacement part may be new or remanufactured. Repair and installation of defective part will be at no charge when product or item is delivered to Subsite or an authorized repair center. The product or item will be returned at no charge for return freight.
- The warranty periods do not represent the useful life of Subsite products and accessories.
- If Subsite products are purchased for commercial purposes, as defined by the Commercial Code, no warranties extend beyond the specific terms set forth in this limited warranty. All other provisions of this limited warranty apply, including the duties imposed.
- Subsite products have been tested to deliver acceptable performance in most conditions.
- This limited warranty applies to the original purchaser only. Some states or jurisdictions do not allow exclusion or limitation of incidental or consequential damages, so above limitation may not apply. This limited warranty gives original purchaser specific rights that vary from state to state or jurisdiction to jurisdiction.
- Each serial-numbered piece of equipment must be registered by the selling dealer to determine warranty start date.
- When a registration is not received, the Subsite shipping date is used to establish the warranty period start date.
- Product inspection and estimates may require that the unit be disassembled and tested.
- Out-of-warranty inspection costs include labor accrued at the full labor rate plus return freight.
- Approved out-of-warranty repair costs include parts, labor accrued at full labor rate, plus return freight.



